

# IQXO-85, -86, -87, -88 Military Oscillator

ISSUE 5; 8 JULY 1999

## Delivery Options

- Please contact our sales office for current leadtimes

## Output Compatibility

- HCMOS/TTL
- Drive Capability: 50pF or 10TTL
- Non tri-state (IQXO-85, -86)
- Tri-state (IQXO-87, -88)

## Package Outline

- 8-pin DIL compatible resistance welded enclosure, hermetically sealed with glass to metal seals and gold plated pins and bases. Available non-screened (IQXO-85, -87) and fully screened (IQXO-86, -88)

## Standard Frequency Stabilities

- $\pm 50$ ppm,  $\pm 100$ ppm  
(inclusive of supply voltage variations over the operating temperature range)

## Frequency Tolerance @ 25°C (Optional)

- $\pm 10$ ppm,  $\pm 25$ ppm

## Operating Temperature Range

- -55 to 125°C

## Storage Temperature Range

- -55 to 125°C

## Screening On Each Device (IQXO-86, -88)

- Acceleration: 49000m/s<sup>2</sup> for 1 minute in the 'Y<sub>1</sub>' plane
- High Temperature Storage: 24hrs at 150°C
- Rapid Change of Temperature: -55 to 125°C, 10 cycles
- Dynamic burn-in for 168hrs at 125°C
- Check all parameters & assess

## Environmental Specification

- Bump: 4000 bumps at 391m/s<sup>2</sup> in each of the three mutually perpendicular planes
- Hermetic Seal: not to exceed  $1 \times 10^{-8}$  mBar litres of Helium leakage
- Humidity: steady state: in accordance with test Ca of IEC 60068-2-3, for 56 days at 40°C at a relative humidity of 93%, cyclic: in accordance with test Db variant 1 of IEC 60068-2-30, at severity b), 55°C for six cycles
- Shock: 981m/s<sup>2</sup> for 6ms, three shocks in each direction along the three mutually perpendicular planes

- Solderability: test IEC 60068-TA
- Vibration: 10 to 60Hz 0.75mm displacement, 60 to 2000Hz 98.1m/s<sup>2</sup> acceleration, 30 minutes in each of three mutually perpendicular planes

## Tri-state Operation (IQXO-87, -88)

- Logic '0' to pin 1 disables oscillator output; when disabled the oscillator output goes to the high impedance state
- No connection or Logic '1' to pin 1 enables oscillator output
- Disable current 50µA typical

## Marking

- Model number
- Frequency Stability Code
- Frequency Tolerance Code (Optional)
- Frequency
- Date Code (Year/Week)

## Minimum Order Information Required

- Frequency + Model Number + Frequency Stability

## Outline in mm

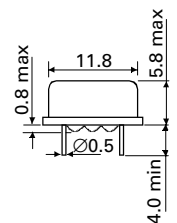

Pin connections  
1. N/C or Enable/Disable.  
4. GND  
5. Output  
8. +Vs

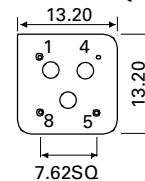

**Electrical Specifications - maximum limiting values when measured in HCMOS test circuit.**

Frequency Range	Frequency Stability	Supply Voltage	Supply Current	Rise Time( $t_r$ )	Fall Time( $t_f$ )	Duty Cycle	Model Number
250.0kHz to < 8.0MHz	$\pm 50\text{ppm}, \pm 100\text{ppm}$	$5V \pm 0.5V$	5mA	10ns	10ns	45/55%	IQX0-85, -86, -87, -88
8.0 to < 23.0MHz	$\pm 50\text{ppm}, \pm 100\text{ppm}$	$5V \pm 0.5V$	10mA	5ns	5ns	40/60%	IQX0-85, -86, -87, -88
23.0 to < 48.0MHz	$\pm 50\text{ppm}, \pm 100\text{ppm}$	$5V \pm 0.5V$	50mA	5ns	5ns	40/60%	IQX0-85, -86, -87, -88
48.0 to 72.0MHz	$\pm 50\text{ppm}, \pm 100\text{ppm}$	$5V \pm 0.5V$	65mA	3ns	3ns	40/60%	IQX0-85, -86, -87, -88

**Ordering Example**

50.0MHz      IQX0-85      B      E

Frequency \_\_\_\_\_

Model number -85,-86 = Non tri-state, -87,-88 = Tri-state \_\_\_\_\_

Frequency Stability: B =  $\pm 50\text{ppm}$ , C =  $\pm 100\text{ppm}$  \_\_\_\_\_

Frequency Tolerance @ 25°C: E =  $\pm 10\text{ppm}$ ; F =  $\pm 25\text{ppm}$  \_\_\_\_\_

Please note: Code combination B F is not available

**Output Waveform - HCMOS/TTL**

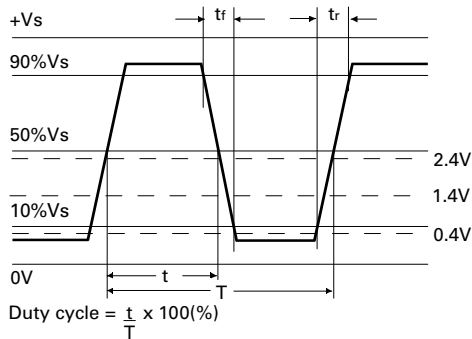

**Test Circuit - HCMOS**

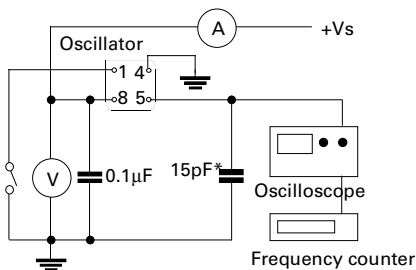

\*Inclusive of jigging & equipment capacitance

Note: Pin 1 = No connection on non tri-state models

**Test Circuit - TTL**

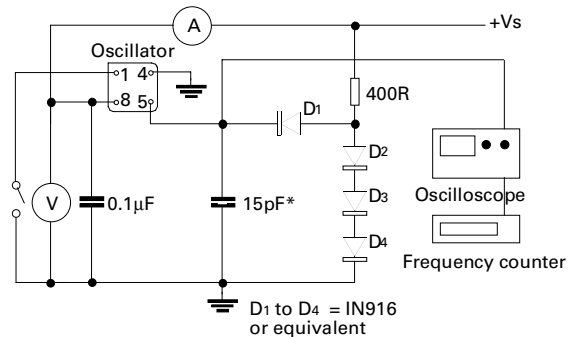

\*Inclusive of jigging & equipment capacitance

Note: Pin 1 = No connection on non tri-state models

LEADED SPX0s